

LAF5S-HB

Next Gen Laser Auto Focus for multi-characteristic surfaces such as semiconductor, wafer with circuit layers on, LCDs, OLEDs and Micro LEDs.

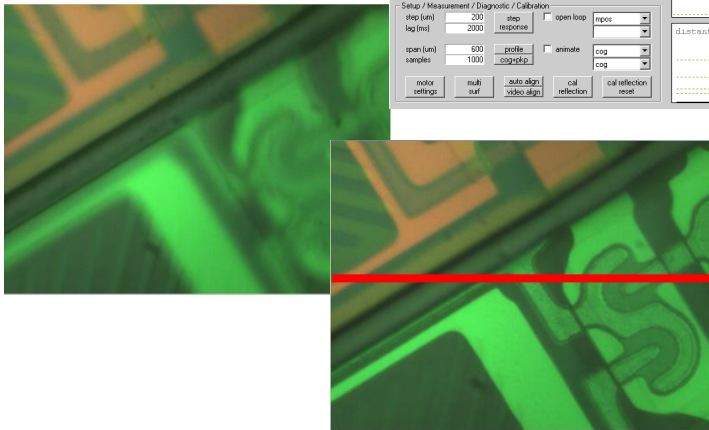
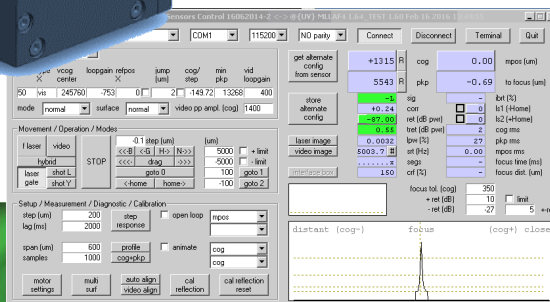
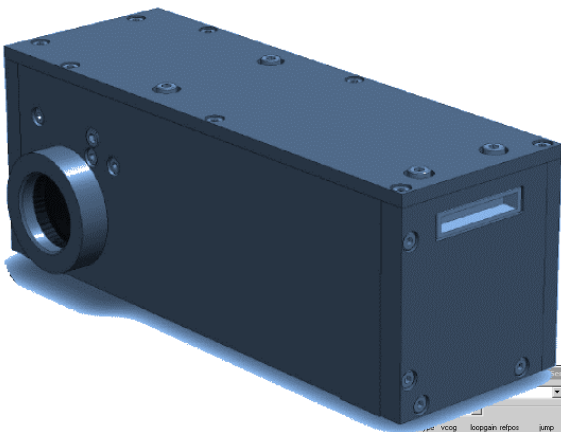

- Full laser line with segment processing
- The unique correlation processing focus technology enables auto focus where other laser or image auto focus systems fail
- Extreme robust focus results by interactive selection of best focus parameters
- Motor controller interface with analog & digital outputs for a seamless closed loop integration with third party's stepper motor, piezo, voice-coil or servo drives
- Applicable to Plan Apo lenses 1x-150x, VIS, IR & UV
- Adjustable laser power limitation
- User interface with enhanced network capabilities for multi sensor operation
- Easy integration of UI functions into the customer software without software library needed

Enables focus tracking where other laser or image auto focus systems fails

- Surfaces with extreme variation of characteristics
- Extreme thin substrate layers (close to DOF of Lens)
- Layers with very weak reflectivity
- Layers with variable reflectivity

Specification LAF5S-HB

Lens Type	APO Plan Infinite Microscope Objective Lens				
Magnification	5x	10x	20x	50x	100x
Numerical aperture	0.14	0.28	0.42	0.55	0.70
Sample rate	4kHz max.				
Image sensor	250 full frames/sec. max.				
Surface detection Range	±12000µm	±4000µm	±1500µm	±300µm	±100µm
Accuracy*	Laser mode: +/-0.4 of Lens DOF				
Light Source	Safety Class III R Wavelength 660nm-670nm, 785nm				
Operation Temperature	+ 5°C to + 50°C				
Beam Shape	45 ° tilted laser line				
Weight Sensor + cable	400gr+ 140gr				
Weight Interface	400gr				
Recommended port	Beamsplitter 50/50 @670nm				
Laser AF Cycle time			0.1s		Auto Tracking
Power	In	+12V DC sensor only, 24-48V sensor with Motor controller			
Distance Output	Analog	0- 10V			
Signal Quality Output	Analog	0- 10V			
Communication	Digital	RS232	Ethernet optional		
Laser ON/OFF	In	TTL	& via command		

*All data refer to measurement on plain glass

Table 1

Working Principle

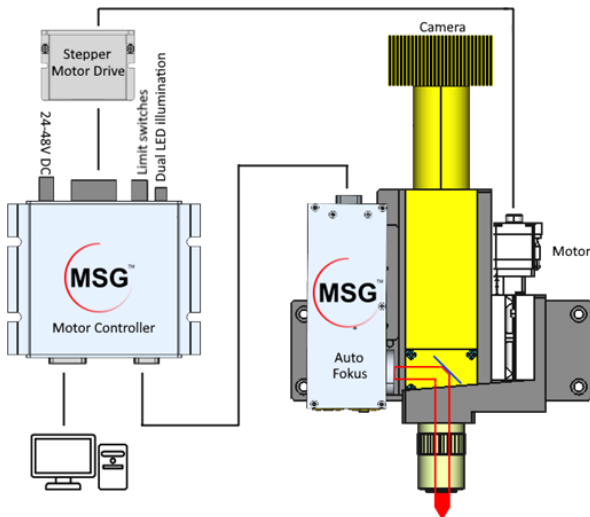

- ① Auto Focus Sensor LAF
- ② LAF controller interface